

FITTING

While fitting NORTHON gear couplings please follow this instructions:

1. Carefully clean both the shafts that will be connected and the holes of the two half-couplings.
2. First fit the gear bell onto the shaft to be connected checking that seal is fitted.
3. Heat up the gear hub to the temperature indicated below in function of the acceptable tolerance.

Tolerance H7/m6	Tolerance H7/n6	Tolerance H7/r6	Tolerance H7/s6
+ 90°	+ 110°	+ 160°	+ 200°

4. Place the hub on the ends of each shaft taking care to prevent it touching the seal while it is still hot.
5. Move the gear bells outwards to uncover the two gear hub as much as possible.
6. Put the shafts to be connected close together until reaching the value "s" indicated in the table.

In order to check this value use a thickness gauge and make sure that the gaps are the same in four different points at 90° (Fig. nr. 1)

7. Check the angular and parallel misalignment of the shaft with a straight edge at two points at 90° of the outer diameter of the hubs (Fig. nr. 2).

Alignment may be considered correct when no light can be see between the straight edge and the hubs.

8. When the hubs are cold, join the two bells using the calibrated screws (to be screwed respecting the tightening torques indicated in the table beneath), then fill the coupling with grease.

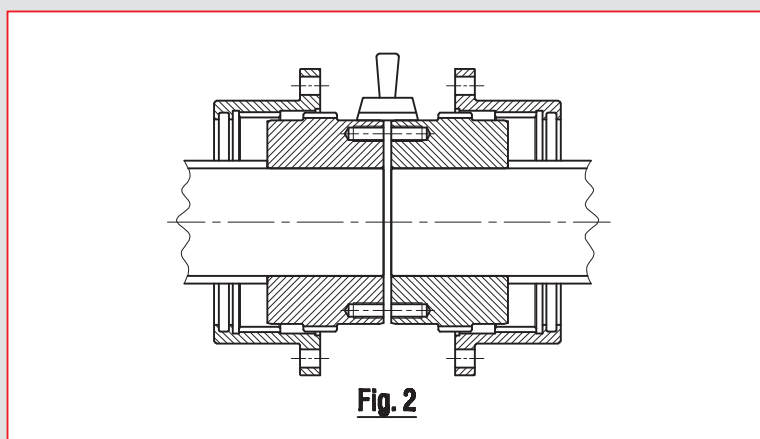
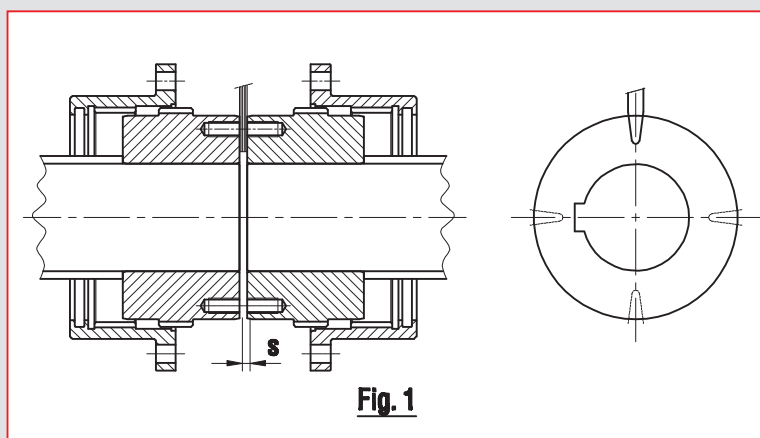

Size	110	142	168	200	225	265	300	330	370	405	440	500	580	630
Nm	19	37	37	63	63	158	158	158	217	415	415	540	540	540
Size	700	760	825	885	935	1010	1085	1185	1340	1440	1575	1705	1805	1935
Nm	1090	1090	1090	1835	1835	1835	2990	2990	4518	4518	4518	7015	7015	7015

It is superfluous to say that the best alignment corresponds to longer service life of the coupling.